

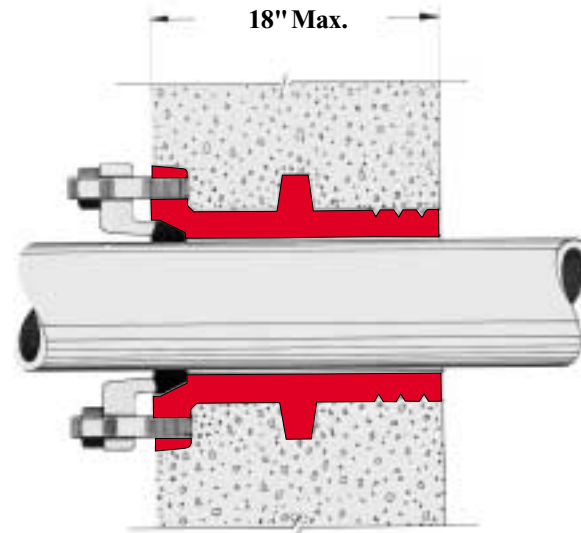

Mechanical Joint Wall Sleeve Model MPS

UNITED BRAND

ANSIA21.10



DIMENSIONS IN INCHES - WEIGHT IN LBS.

Part No.*	Nominal Pipe Size	Bell O.D.	Water Stop O.D.	Inside Diameter	Weight (18" length)	Stud Bolts	
						Size	No. Req'd.
MPS04C	4	9.12	8.0	4.90	60	3/4 x 3 1/2	4
MPS06C	6	11.12	10.0	7.0	85	3/4 x 3 1/2	6
MPS08C	8	13.37	12.5	9.15	115	3/4 x 3 1/2	6
MPS10C	10	15.69	14.5	11.20	160	3/4 x 3 1/2	8
MPS12C	12	17.94	16.5	13.30	190	3/4 x 3 1/2	8
MPS14C	14	20.31	21.5	15.44	260	3/4 x 4	10
MPS16C	16	22.56	23.5	17.54	310	3/4 x 4	12
MPS18C	18	24.83	26.0	19.64	370	3/4 x 4	12
MPS20C	20	27.08	28.0	21.74	430	3/4 x 5	14
MPS24C	24	31.58	32.5	25.94	580	3/4 x 5	16

1. The sleeve is grooved in 2" intervals to facilitate cutting in the field.
2. May be ordered cut to length.
3. Integral Wall Collar 4" from MJ Bell.
4. MJ Bell and Bolt hole arrangement in accordance with AWWA C110 and tapped for studs 3/4" - NC.

Material: Gray Cast Iron ASTM A126, Class 30.

*Ductile Iron ASTM A536 (Suffix D) Available appx. 90 days ARO.

Coating & Lining: Bituminous

Form No. FP0180

Note: Design subject to change without notice.

Fab pipe inc.

21425 147th Ave. N., Rogers, MN 55374
Tel: (763) 428-2259 • Fax: (763) 428-4978



011