



Steel Wall Sleeves



ASTM A-53 • ASTM A-36

Plain end steel wall sleeves are employed (with rubber sealing link arrangements) to provide a watertight seal around pipe penetrations through concrete walls. When compressed the rubber links expand to fill the annular space between the outside of the carrier pipe and the inside surface of the wall sleeve. Steel wall collars are attached to the OD of the sleeve by means of continuous automatic arc welding to achieve a watertight seal.

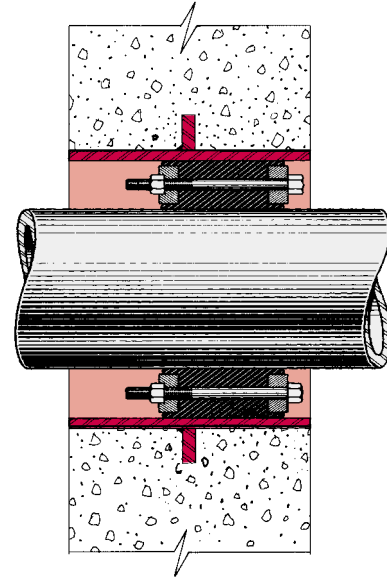

STANDARDS

Sleeves are fabricated from steel pipe conforming to ASTM A-53 ERW Schedule 40 (3"-12") or standard .375 wall (14"+) unless specified otherwise. Wall collars are produced from steel conforming to ASTM A36.

Steel Wall Sleeve Selection Chart

DI Carrier Pipe Size	Steel Wall Sleeve			
	Pipe Size	OD	ID	WC OD (Min.)
3	6	6.62	6.06	9.62
4	8	8.62	7.98	11.62
6	10	10.75	10.02	13.75
8	12	12.75	12.00	15.75
10	14	14.00	13.25	18.00
12	16	16.00	15.25	20.00
14	18	18.00	17.25	22.00
16	20	20.00	19.25	24.00
18	24	24.00	23.25	28.00
20	26	26.00	25.25	30.00
24	30	30.00	29.25	34.00
30	36	36.00	35.25	40.00
36	42	42.00	41.25	46.00

COATING & LININGS

Unless otherwise specified, steel wall sleeves are furnished with a bituminous coating and lining per ANSI/AWWA C151/A21.51. Special primers, epoxies and other special coatings are available upon request. Galvanized wall sleeves are also available.

LENGTH

Wall sleeves, though generally no longer than the thickness of the concrete wall, may be ordered up to 21'0" in length.

NOTE: The critical positioning of wall sleeves within forms may require the overall length tolerance be revised to $+0/-0.125"$. These installations must be specified by the purchaser.

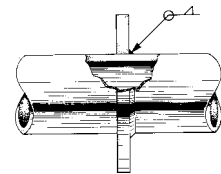

Note: Design subject to change without notice.

Form No. FP0045

Fab pipe inc.



21425 147th Ave. N., Rogers, MN 55374
Tel: (763) 428-2259 • Fax: (763) 428-4978

