

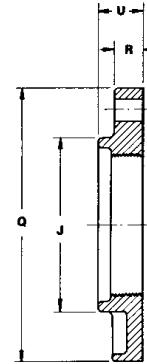

Ductile Iron Threaded Flange Model FDL

UNITED BRAND

ANSI B16.1 Class 125

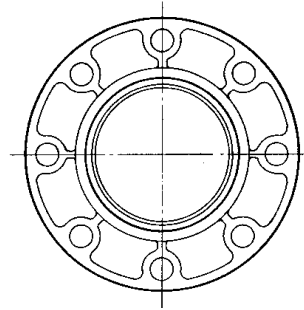
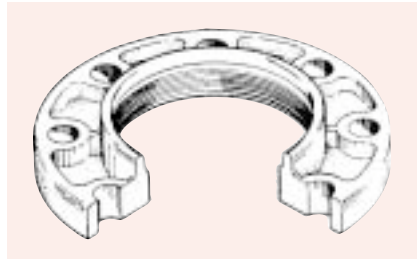

Nom. Pipe Size	Rough O.D. of Pipe	Flange Thk. R	Overall Thk. U	Length of Thread	O.D. of Flange Q	Hub Dia. J	Weight	Bolt Circle	Bolt Hole Dia.	Bolt Dia & Length	No. of Bolt Holes
3	3.96	0.75	1.50	0.94	7.50	4.50	5	6.00	3/4	5/8 x 2 1/2	4
4	4.80	0.94	1.62	1.00	9.00	5.32	10	7.50	3/4	5/8 x 3	8
6	6.90	1.00	1.75	1.16	11.00	7.56	15	9.50	7/8	3/4 x 3 1/2	8
8	9.05	1.12	2.41	1.37	13.50	9.73	20	11.75	7/8	3/4 x 3 1/2	8
10	11.10	1.19	2.46	1.50	16.00	12.06	30	14.25	1	7/8 x 4	12
12	13.20	1.25	2.67	1.75	19.00	14.16	44	17.00	1	7/8 x 4	12
14	15.30	1.37	2.50	1.87	21.00	16.25	56	18.75	1 1/8	1 x 4 1/2	12
16	17.40	1.44	2.75	2.06	23.50	18.44	66	21.25	1 1/8	1 x 4 1/2	16
18	19.50	1.56	3.00	2.25	25.00	20.53	85	22.75	1 1/4	1 1/8 x 5	16
20	21.60	1.69	3.25	2.44	27.50	22.63	95	25.00	1 1/4	1 1/8 x 5	20
24	25.80	1.88	3.50	2.75	32.00	26.82	125	29.50	1 3/8	1 1/4 x 5 1/2	20
30	32.00	2.12	3.88	3.37	38.75	32.75	210	36.00	1 3/8	1 1/4 x 6 1/2	28
36	38.30	2.38	4.49	4.00	46.00	39.12	320	42.75	1 5/8	1 1/2 x 7	32
42	44.50	2.62	5.12	4.50	53.00	45.31	450	49.50	1 5/8	1 1/2 x 7 1/2	36
48	50.80	2.75	5.24	5.12	59.50	51.75	565	56.00	1 5/8	1 1/2 x 8	44

1. Flanges are fully machined, drilled and faced in accordance with ANSI B16.1 Class 125.
2. Flanges are threaded in accordance with ANSI B1.20.1
3. Manufactured from ductile iron ASTM A536
4. For use with AWWA ductile iron pipe, fabricated in accordance with AWWA C115 (ANSI A21.15).
5. Dimensions are in strict accordance with AWWA C115, Table 3.

Dimensions in inches
Weights in lbs.

Form No. FB0034

Fab pipe inc.

011



21425 147th Ave. N., Rogers, MN 55374
Tel: (763) 428-2259 • Fax: (763) 428-4978

